

DISC BRAKE – MODEL SKP 140 SA

SPRING APPLIED, HYDRAULIC PRESSURE RELEASED
SINGLE ACTING DISC BRAKE

The Dellner Brakes Single Acting model SKP 140-SA is a spring applied, hydraulically released caliper disc brake, which offers a reliable and safe method of braking linear or rotary motion.

The Single Acting brake is largely designed with internal parts from Dellner Brakes Double Acting brake, the SKP, a well proven concept.

The Single Acting brake is self aligning and is thus well suited for applications with axial movements or limited installation space.

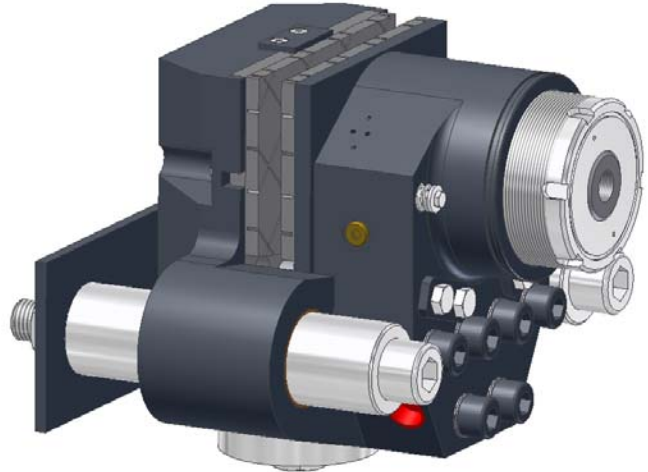

Moreover, it consists of one cylinder housing and a robust low friction sliding system that enables self alignment.

In order to compensate for friction pad wear and to maintain full brake capacity, the spring pack must be adjusted a few times during the life span of the friction pad. The unique, well proven Dellner Brakes design, with an extension of the brake piston through the cylinder provides an easy visual way to tell when adjustment is needed. The SKP 140 is equipped with “Easy Adjustment-arrangement” as standard.

As an option, the brakes can be equipped with proximity switches to indicate brake ON/OFF, PAD WEAR and/or NEED OF ADJUSTMENT.

Dellner Brakes also offers a Standard and Off-shore version as well as a variety of different friction and seal materials to fit any application demands.

Model	Tangential braking force F		Releasing pressure [bar] ⁴⁾	Air gap between brake disc and lining [mm]		Estimated life of disc spring pack [no. Of strokes]		Friction area per brake [cm ²]	Weight [kg]
	max. ²⁾	min. ³⁾		min. ⁵⁾	max. ⁶⁾	min. ⁷⁾	max. ⁸⁾		
SKP 140-26 SA	32800	26200	50	2x1,0	2x2,0	>2x10 ⁶	>2x10 ⁶	828	216
SKP 140-42 SA	46400	41900	65	2x1,0	2x2,0	>2x10 ⁶	>2x10 ⁶	828	216
SKP 140-53 SA	62900	53200	90	2x1,0	2x2,0	>2x10 ⁶	>2x10 ⁶	828	216
SKP 140-63 SA	72100	62900	100	2x1,0	2x2,0	>2x10 ⁶	>2x10 ⁶	828	216
SKP 140-71 SA	90600	71200	135	2x1,0	2x2,0	≤1,12x10 ⁶	≤1,12x10 ⁶	828	216
SKP 140-86 SA	104600	85900	150	2x1,0	2x2,0	≤3,97 x10 ⁵	≤3,97 x10 ⁵	828	216
SKP 140-95 SA	113600	95300	160	2x1,0	2x2,0	≤1,38 x10 ⁵	≤1,38 x10 ⁵	828	216

- 1) Calculated with an average frictional coefficient $\mu=0,42$. Consideration has not been taken for external factors.
- 2) Braking force with correctly adjusted disc spring pack.
- 3) Braking force with maximum recommended air gap before adjustment is needed.
- 4) Pressure to fully release brake.
- 5) Air gap for correctly adjusted brake.
- 6) Maximum recommended air gap before adjustment is needed.
- 7) Valid for minimum spring pack compression.
- 8) Valid for maximum spring pack compression.



Torque table

The braking torque is calculated from the following formula:



$$M_{brake} = \frac{q \times F_b \times (D_s - 2h)}{2}$$

- q = number of brakes
 F = braking force according to the table below [N]
 D_s = brake disc diameter [m]
 h = constant for effective radius [m] (SKP 140 = 0,08)

Brake model	Tangential braking force F [N] ¹⁾		Disc diameter D [mm]							
	max. ²⁾	min. ³⁾	ø700	ø800	ø900	ø1000	ø1200	ø1400	ø1600	ø1800
SKP 140-26 SA	32800	26200	7070	8380	9690	11000	13620	16240	18860	21480
			8855	10495	12135	13775	17055	20335	23615	26895
SKP 140-42 SA	46400	41900	11310	13405	15500	17595	21785	25985	30165	34355
			12525	14845	17165	19485	24125	28765	33405	38045
SKP 140-53 SA	62900	53200	14360	17020	19680	22340	27660	32980	38300	43620
			16980	20125	23270	26415	32705	38995	45285	51575
SKP 140-63 SA	72100	62900	16980	20125	23270	26415	32705	38995	45285	51575
			19465	23070	26675	30280	37490	44700	51910	59120
SKP 140-71 SA	90600	71200	19220	22780	26340	29900	37020	44140	51260	58380
			24460	28990	33520	38050	47110	56170	65230	74290
SKP 140-86 SA	104600	85900	23190	27485	31780	36075	44665	53255	61845	70435
			28240	33470	38700	43930	54390	64850	75310	85770
SKP 140-95 SA	113600	95300	25730	30495	35260	40026	49555	59085	68615	78145
			30670	36350	42030	47712	59070	70430	81790	93150







- 1) Calculated with an average frictional coefficient $\mu=0,42$. Consideration has not been taken for external factors.
- 2) Braking force with correctly adjusted disc spring pack.
- 3) Braking force with maximum recommended air gap before adjustment is needed.

Options

-  Proximity or mechanical switches for indicating on/off, pad wear or "time to adjust".
-  Adjustment nut protection cover

Suitable applications

Dellner Brakes model SKP 140 is suitable wherever safety brakes are needed, for example in the following types of applications:

-  Cranes
-  Conveyors
-  Emergency stops
-  Winches
-  Wind mills
-  Parking applications